



MeacoClean CA-HEPA 119x5 Air Purifier



Thank you for choosing Meaco, we really do appreciate it

INSTRUCTION MANUAL [EN]

CA-HEPA 119x5

ATTENTION

This air purifier must not be used in rooms under the following conditions:

- Potentially explosive atmosphere
- Aggressive atmospheres
- For use in domestic applications only

Keep Children and Pets Away: Do not allow children or pets to play with or around this unit, which could result in injury. Be sure the unit is inaccessible to children when not attended.

The appliance is not to be used by persons (including children) with reduced physical, sensory or mental capabilities, or a lack of experience and knowledge, unless they have been given suitable supervision and/or instruction.

Keep Unit Grounded: Always operate the unit with a grounding plug and a grounded electrical outlet. A grounding plug is an essential safety feature that helps reduce the risk of shock or fire.

Protect Power Cord from Damage: Do not run power cord under carpeting, or cover with rugs or runners. Arrange the cord away from areas where it may be tripped over. Never operate a unit with a damaged power cord, as this may lead to electrical or fire hazards. If the power supply cord is damaged, it must be replaced by a cord of the same type and amperage rating.

Extension Cords: Where possible, avoid the use of an extension cable as they may overheat and cause a risk of fire. Only use an extension cord after ensuring it is in perfect condition. Extension leads can also cause voltage drop which will affect the air purifier. This is more likely when being used in out buildings.

Handle with Care: Do not drop, throw or crash the air purifier. Rough treatment can damage the components or wiring and create a hazardous condition.

Run on Stable Surface: Always operate the unit on a stable, level surface, for example the floor or a strong counter, so that the air purifier cannot fall and cause injury.

Keep Out of Water: Never operate the unit in pooled or standing water, as this may create a risk of injury from electrical shock. Do not store or operate outdoors. If electrical wiring or components become wet, thoroughly dry them before using the unit. If in doubt do not use the air purifier and consult a qualified electrician or a Meaco approved engineer.

Keep Air Intakes Clear: Do not clog or block the air intakes by placing the air purifier too close to curtains, walls or anything that will restrict the air inlet. This may cause the unit to overheat and result in a fire or electrical hazard.

Keep Filter Clean or Replace: Always use a clean air filter. Do not allow any material to clog the filter, as this may cause the air purifier to overheat. Never use without a filter, if the filter is blocked then it is time to buy replacement filter set. Always check, and if necessary, clean or replace the filter before switching the air purifier on. Do not allow oil, grease, or other contaminants to be drawn into the air purifier. Do not clean the air purifier with organic solvents.

A Clean Filter is Important: Check the filter regularly in order to keep it clean as per the instructions in this manual. A dirty filter will restrict the air flow into the machine which will increase the resistance on the fan and could result in damage and might invalidate the warranty. The power light will flicker when the filters have come to the end of their natural life.

The operator must make the operating instruction available for the user and make sure that the user does understand the manual.

Turning off: Never unplug the power cord without pressing the "Power" key to off first, as this could damage the unit. Always unplug the unit when not in use or moving location. To disconnect from the power supply, grip the plug and pull from the power socket. Never pull by the cord.

Repairs: To repair the unit, take it to a qualified service engineer. Repairs carried out by unqualified people may cause damage to the unit or injury to persons or property and void the warranty.

BS PLUG WIRING

Wiring Instructions: Should it be necessary to change the plug please note the wires in the mains lead are coloured in accordance with the following code:

BLUE – NEUTRAL

BROWN - LIVE

As the colours of the wires in the mains lead of this appliance may not correspond with the coloured markings identifying the terminals in your plug, proceed as follows:

1. The **BLUE** wire is the **NEUTRAL** and must be connected to the terminal which is marked with the letter **N** or coloured **BLACK**.
2. The **BROWN** wire is the **LIVE** and must be connected to the terminal which is marked with the letter **L** or coloured **RED**.
3. Always ensure that the cord grip is positioned and fastened correctly.

If a 13A (BS1363) fused plug is used it must be fitted with a 3A fuse. If in doubt consult a qualified electrician.

Wiring for a 13Amp Plug (BS1363)

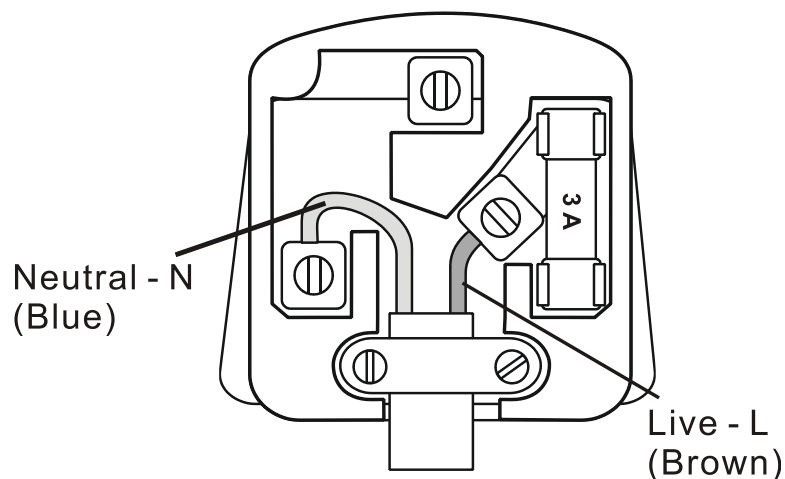

1. GENERAL ADVICE

Before putting your air purifier into operation for the first time, the instruction manual should be studied carefully.

After receiving the unit, you should check your air purifier for any transport damage. In case of damage, you should inform the sender immediately.

Keep the packaging for the air purifier in a safe place in order to be able to despatch the air purifier safely if it requires a service. In order to save space, you can simply cut through the adhesive tape using a knife and fold up the cardboard box. Please keep all packaging away from children and recycle the packaging if you do decide to dispose of it.

2. AIR PURIFIER PRINCIPLES

This air purifier uses a multi-stage air cleaning system. The room air first moves across the pre-filter to remove larger particles such as dust from the air. The charcoal filter then removes smells from the air, next the HEPA filter removes smaller allergens from the air and finally the ultra violet light works in conjunction with the photocatalyst titanium dioxide coating to remove bacteria, viruses, odours and VOCs from the air. The ioniser helps to remove extra dust and odours from the air.

The more times that the air within the room passes through the air purifier the cleaner the air will become. This is why it is important to carefully size the air purifier to your room size. Look for a minimum of three air changes per hour through the air purifier, we use five air changes per hour as a guide when sizing the machine up.

3. INSTALLATION AND INITIAL USE

- Place the air purifier in an upright position on a stable, flat surface.
- When moving the air purifier always lift using the handle on the rear of the machine
- Please ensure the unit is a safe distance away from a wall or furniture, at least 30 cm is recommended.
- Remove the filters from their bags and place them inside the air purifier as per below
- Plug the air purifier into an appropriate wall plug socket.

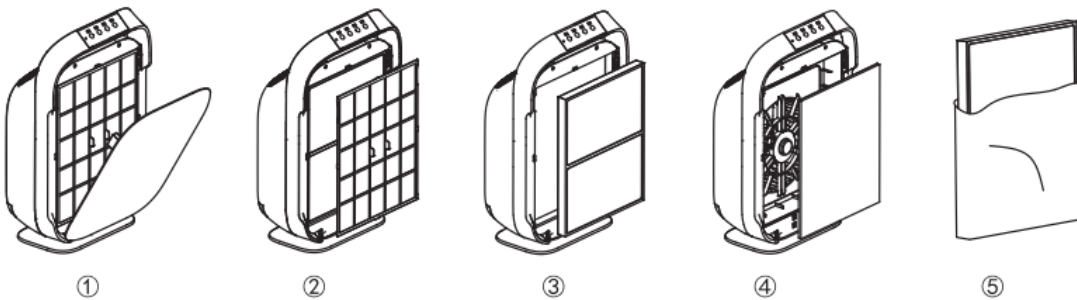

1. Place your fingers in the recesses of the side panels and gently pull the top part of the front panel towards you. Then lift the panel up and away from the main body.
2. Remove pre-filter from the appliance.
3. Remove the HEPA filter from the appliance.
4. Remove the Activated Carbon filter from the appliance.
5. Remove all packaging material from the filters. Dispose of the packaging carefully and keep away from children.
6. Place the Activated Carbon filter back into the appliance, make sure the side with the tab faces towards you.
7. Place the HEPA filter back into the appliance, make sure the side with the tab faces towards you.
8. Place the Pre-filter back in the appliance, make sure the side with flange faces towards you.
9. To reattach the front panel, insert the bottom end first. Then push the panel against the body of the machine.

PRODUCT IDENTIFICATION

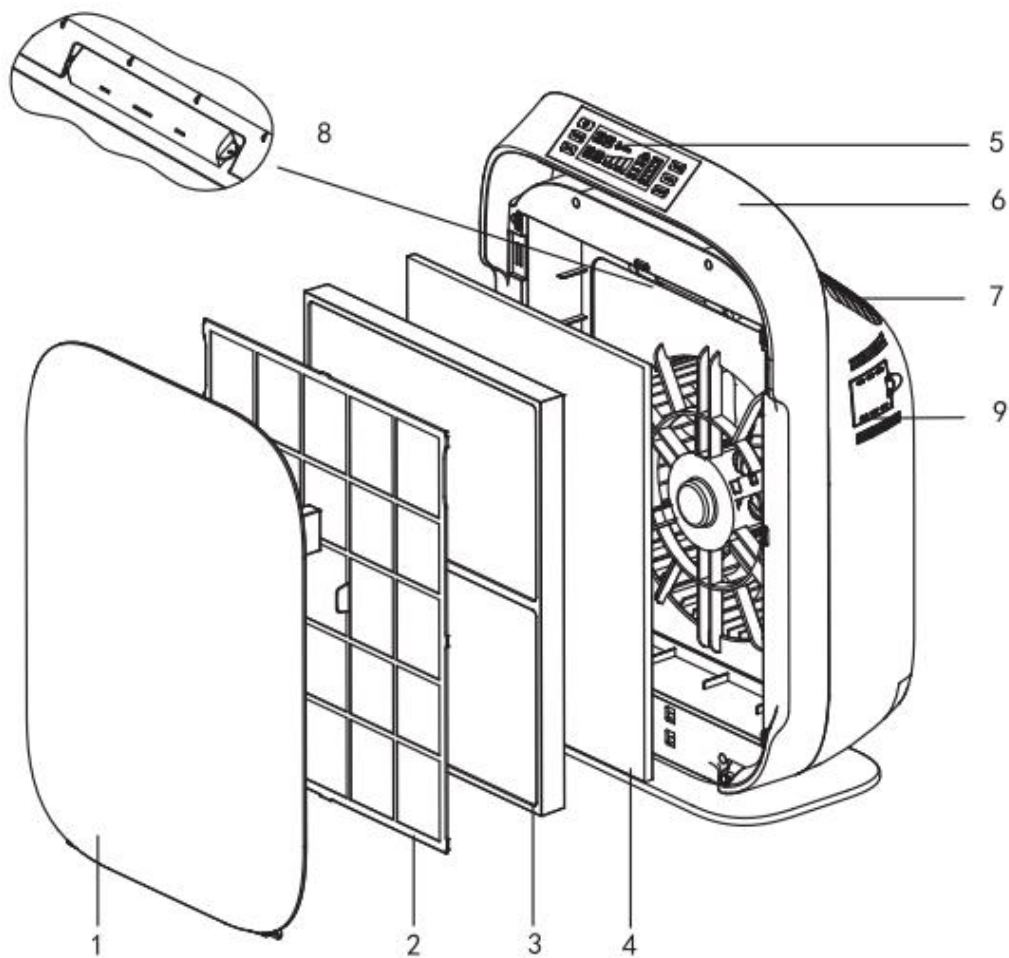

1. Front cover
2. Pre-filter
3. HEPA filter
4. Activated Carbon filter
5. Control panel
6. Handle
7. Air outlet
8. UV-C lamp + PCO device
9. Dust sensor and Filter reset button

10. CONTROL PANEL AND OPERATION

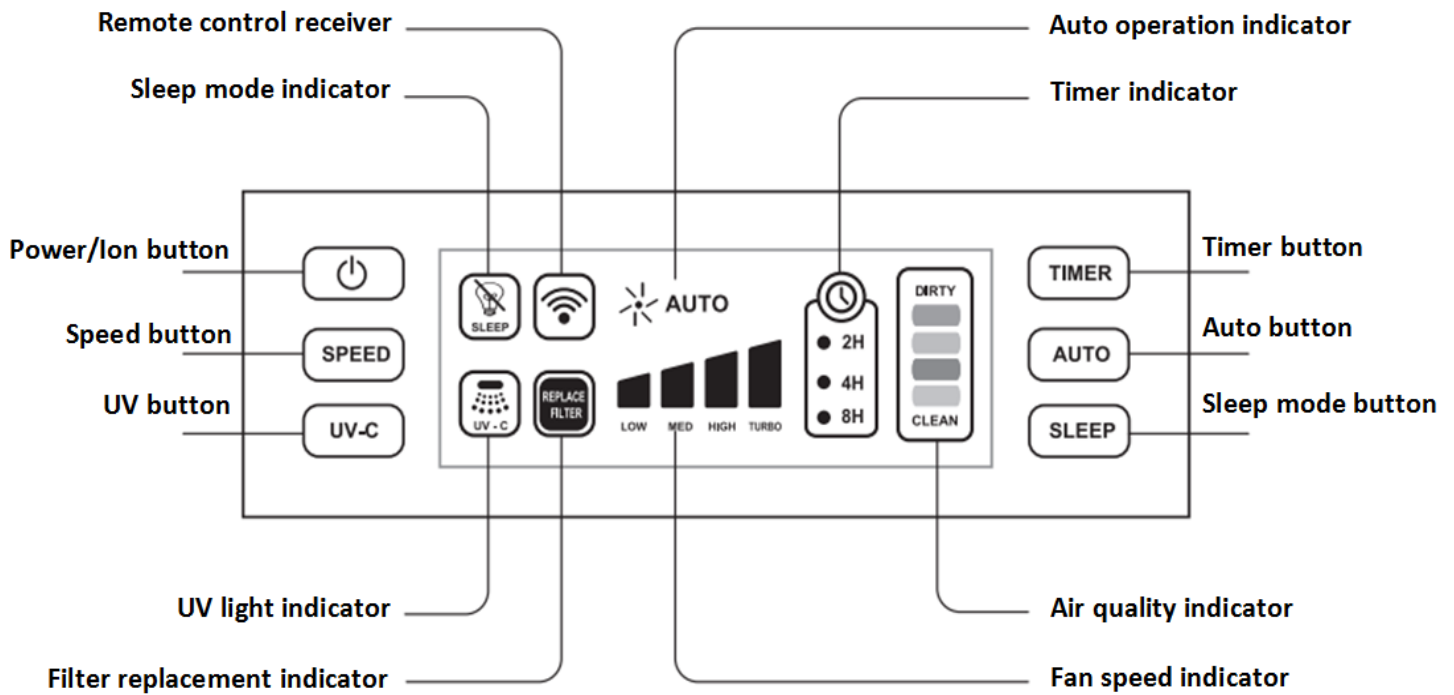

Power button: press this button to start and shutdown the appliance, the Ioniser generator will start and shutdown at the same time.

Fan speed button: press this button one or more times to select the desired fan speed. The corresponding fan speed light indicate the fan speed (Low, Medium, High, Turbo).

UV-C button: press this button and the corresponding light will indicate the UV lamp operation.

Timer button: press this button one or more times and the corresponding light will indicate the operation off time you have set. If you wish to run the air purifier continuously then the Timer should not be activated.

Auto button: press this button the appliance will adjust the fan speed automatically according to the room air quality.

Sleep mode button: press this button and the LED light will turn off while the appliance keeps on operating.

Operation guidance

Fan speed indicator

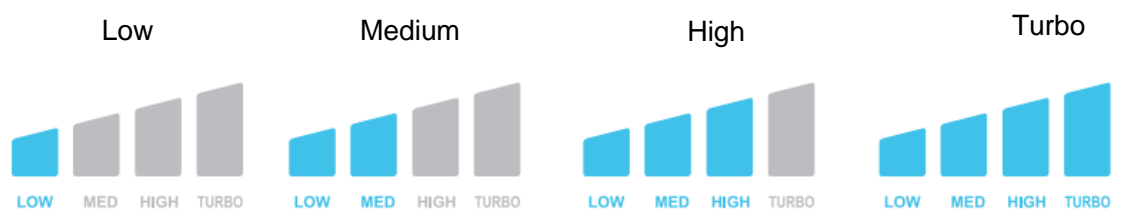

Timer indicator

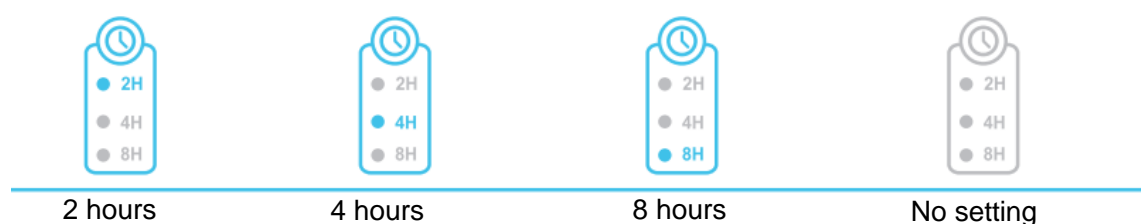

UV light



UV light



UV light off

Auto operation indicator



Auto operating



Manual operation

Air quality



Dirty	(Red)
Bad	(Orange)
Normal	(Yellow)
Clean	(Blue)

There are four different colours of the light to indicate four different levels of air quality. The corresponding colour of the light indicates the air quality in your room.

▲ Sleep mode

-When you press the "SLEEP" button, the sleep mode indicator will light for 10 seconds, all of the LED lights turn off, but the appliance keeps operating in its previous setting.

11. FILTER REPLACEMENT

HEPA filter and Activated Carbon filter change: After operating 4320 hours (approximately 6 months), the “replace filter” light will come on (a blue light) to remind you to change the filters.

After replacing the filters you need to press the reset button to start the next 6 months cycle.

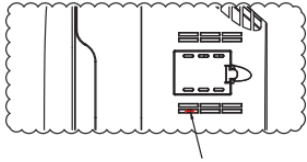

Reset button

Note: The HEPA filter and the activated carbon filter have a similar lifetime, this is why they should be replaced at the same time.

1. Turn the air purifier off and remove the plug from the socket.
2. Open the front cover from the top.
3. Remove the HEPA and Charcoal filters by pulling the two tabs.
4. Insert the replacement filters into the unit. Consult the strips on the filter for correct installation direction.
5. Clean the pre-filter if required.
6. Re-fit the pre-filter.
7. Reattach the front cover of the unit and securely latch into place.
8. Turn the air purifier back on.
9. Reset the change filter button as per above.

12. CLEANING AND UVC REPLACEMENT

The air purifier should be cleaned at least once every month and the Pre-Filter should be cleaned every month. More frequent cleaning may be required depending on environmental conditions.

FILTERS

Clean with the brush attachment of your vacuum cleaner. This will remove lint and dirt.

NOTE:

-Only the **Pre-filter** is washable. And make sure the pre-filter is dry when you put it back in the air purifier..

PCO life time

-About 2 years.

UV LAMP REPLACEMENT

1. Turn the air purifier off and remove the plug from the socket.
2. Open the UV lamp cover using a screw driver.
3. The UV Bulb is removed by carefully grasping the bulb with a clean cloth or tissue and twisting the bulb 1/4 turn.
4. Take out the UV lamp from the holder carefully and unplug the connector.
5. Connect the new UV lamp to the connector and fix back the lamp to the holder carefully.

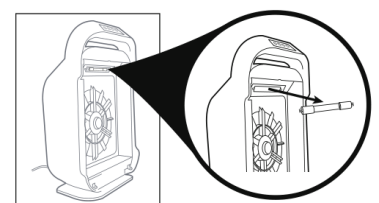

Note: Do not look at an operating UV lamp directly as this could seriously damage your eyesight

Product cleaning

- Make sure you unplug the air purifier before cleaning the appliance.
- Do not put the appliance into water or use water directly on the appliance to clean it.
- Do not use any corrosive or flammable detergent to clean the appliance.
- Please do use a soft cloth with a mild household cleaner to clean the appliance, and make sure the appliance is dry after cleaning.
- Regularly clean the inside and surface, to prevent dust gather.
- Regularly clean the air inlet and air outlet.
- Regularly clean the dust sensor by a cotton swab as per below to maintain its sensitiveness.

Dust sensor cleaning

Clean the dust sensor every 2 months for optimal functioning of the appliance. Clean it more frequently if you use the appliance in a dusty environment.

1. Clean the dust sensor inlet and outlet with a soft brush.
2. Open the dust sensor cover.
3. Clean the dust sensor, the dust inlet and the dust outlet with a lightly moistened cotton swab.
4. Dry them with a dry cotton swab.
5. Reattach the air quality sensor cover.

Note: Do not use any corrosive or flammable detergent to clean the appliance, in case any damage.

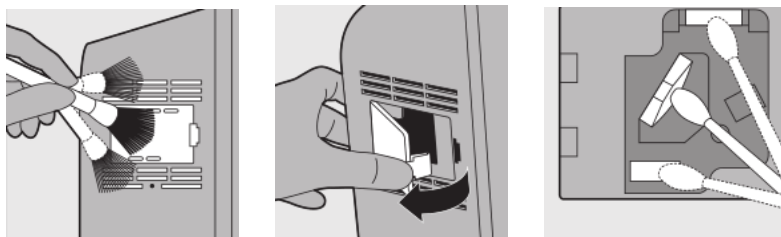

13. ELECTRICAL CONNECTIONS

This air purifier was designed to operate in a 230V~50Hz electrical installation. Make sure that the electric sockets are connected to earth and that all safety precautions are taken.

Model	MeacoClean CA-HEPA 119x5
Noise level – L/M/H fan speeds	29/45/57/62dB
Air flow	595 cubic metres per hour
Rated Voltage	220 - 240V / 50Hz
Power Consumption	70 watts
Ultra Violet light	254 nanometers
Lamp life	Approximately 10,000 hours
Air purifier Dimensions (mm)	445 x 238 x 680 (LWH)
Weight (Kgs)	8.3Kgs

14. SPECIFICATIONS

This product complies with the maximum allowable concentration of ozone of 0.050 parts per million by volume (ppmv) in a 24-hour period. The Health Canada Guideline 2010 (ISBN 978-1-100-16288-1) recommends that the maximum exposure limit, based on an average time of 8 hours, is 0.020 ppmv or less when tested in a sealed, controlled room approximately 30m³.

15. TROUBLESHOOTING

Trouble	Cause	Solution
Unit does not operate	No power to the unit	Plug in the unit; check power at outlet
	On/Off not turned ON	Press the power button
	Front cover not in place	Securely fit the front cover
Restricted air flow	Dirty filters	Clean or replace filters
	Blocked inlet/outlet	Remove blockage, position further away from furniture/walls/curtains etc.
Excessive noise	Uneven surface	Only use on a flat and level surface
	Blocked filters	Clean or replace filters
	Foreign object touching the fan	Check that nothing has entered the air purifier and is touching the fan.

16. WARRANTY AND CUSTOMER SERVICE

There is a two year warranty on your air purifier from the date of purchase.

All material or manufacturing defects will be repaired free of charge.

The following applies:

- Any repairs or replacement of components during the warranty period will not result in an extension of the warranty period.
- The warranty will expire if any alterations have been made, not genuine components have been fitted or if the air purifier has been repaired by a third party.
- Components subject to normal wear and tear, such as the air filter, are not covered by the warranty.
- The warranty is only valid on presentation of the original, unaltered, and date-stamped purchase receipt.
- The warranty does not cover damage caused by actions that deviate from those as described in the user's manual or by neglect.
- The warranty does not cover faults caused by dirt or third party products.
- The warranty does not cover accidental damage.
- All claims for compensation, including consequential damage, will not be entertained.

To prevent unnecessary expenses, we recommend that you always carefully read the user's manual first. If this does not provide a solution, call Meaco and we will be happy to help.

This appliance is not intended for use by persons (including children) with reduced physical, sensory or mental capabilities, or lack of experience and knowledge, unless they have been given supervision or instruction concerning use of the appliance by a person responsible for their safety.

Children should be supervised to ensure that they do not play with the appliance.

This air purifier has been imported into the U.K. by;

Meaco (U.K.) Limited
Meaco House
Parklands
Railton Road
Guildford
GU2 9JX

Telephone: 01483 234900
Email: sales@meaco.com
Website: www.meaco.com
Fax: 01483 232700

Please record, for future reference, your date of purchase and where you bought the air purifier from here.

Date of purchase.....

Purchased from www.meaco.com (if not then please record the supplier's name below).

.....

Meaco are specialists in air purifiers and would welcome your comments and questions on this air purifier. If you do develop a fault within the first year then please do call us and if we cannot fix the problem over the phone we will be happy to collect the air purifier from you at our expense and repair or replace as appropriate.

Please save the box just in case this happens.